

# An LED trans-illuminator for the Nikon TE300 microscope

## 1. Introduction

We describe a white light light-emitting diode (LED) transillumination light source which can be used to replace the tungsten lamp illuminator used with older style (e.g. TE300) Nikon microscopes. There are several reasons why one might want to replace the tungsten source: less heat is produced, improved control and stability of colour temperature when the light output is changed is obtained, elimination of lamp position adjustment and longer lamp life. In our case there was an additional desirable requirement: we wanted to place the complete microscope in an environmentally controlled enclosure, with both fluorescence excitation and trans-illumination lamphouses outside the enclosure; the usual Nikon fitting is rather cumbersome to 'split' and it is rather hard to fashion a suitable cut-out in the rear wall of the enclosure. By using a round fitting, as described here, these issues are overcome and all the usual advantages of LED illumination are realised.

## 2. The LED illuminator

The illuminator mechanics are shown in Figure 1. We use a 40 mm diameter, 28.5 mm focal length aspheric lens to collect as much light as is practicable in an assembly which can fit in the 60 mm diameter circular port of the TE300 microscope; this port accepts the usual tungsten lamphouse. The illuminator consists of the following components, shown later in detail: the body, which holds the lens, a lens clamp ring, a threaded LED mount, used to focus the LED so that a collimated beam is obtained, and a series of heatsink fins which are all clamped together and attached to the LED mount. A connector, mounted in the last heatsink fin, completes the assembly.

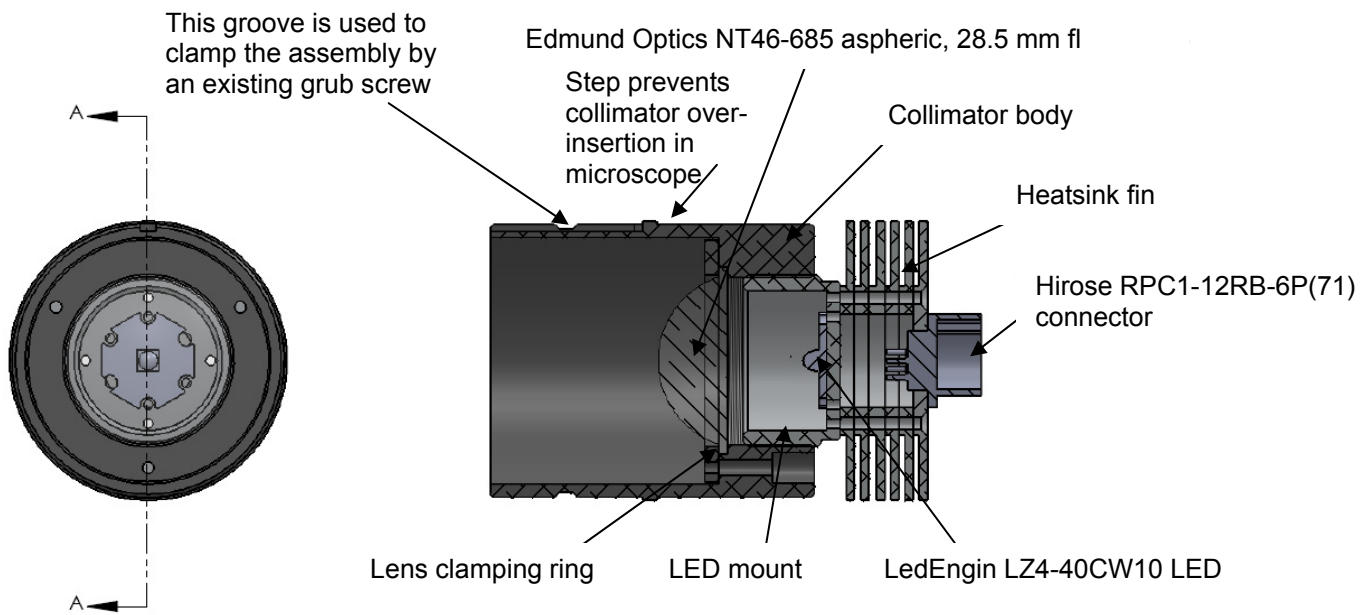
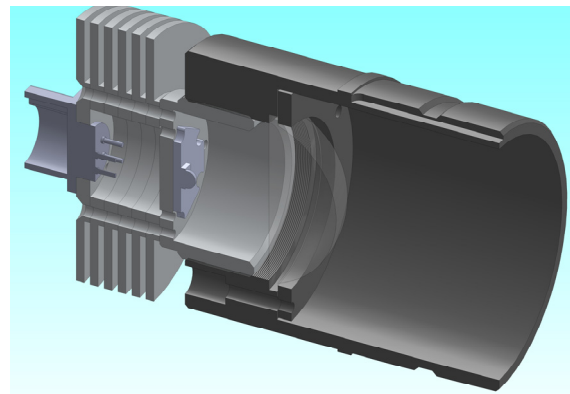

Figure 1: Details of the collimated LED white light source mechanical system (top) and a 3D cutaway model (right).



This method of construction allows easy assembly and access to all the components if required. The LED is already mounted on the common ‘star’ type of fixture. Thermally conductive compound is applied to the LED before it is fixed onto the threaded LED mount; connections to the LED are taken through two holes and are paced in a void created in the heatsink fins and finally connected to the input connector which is screwed into the final fin tapped holes. Thermally conductive compound is also applied between the fins, which are held together by countersunk screws fitted to holes in the LED mount. We found it easier to machine separate fins rather to machine thin slots in a block. Although the thermal resistance is undoubtedly higher than would have been the case if a single block had been used, it is quite adequate for this purpose; temperature rise at full output was negligible. Detailed drawings of the collimator body, the LED mount, and the heatsink fins are provided in Figures 2-4.

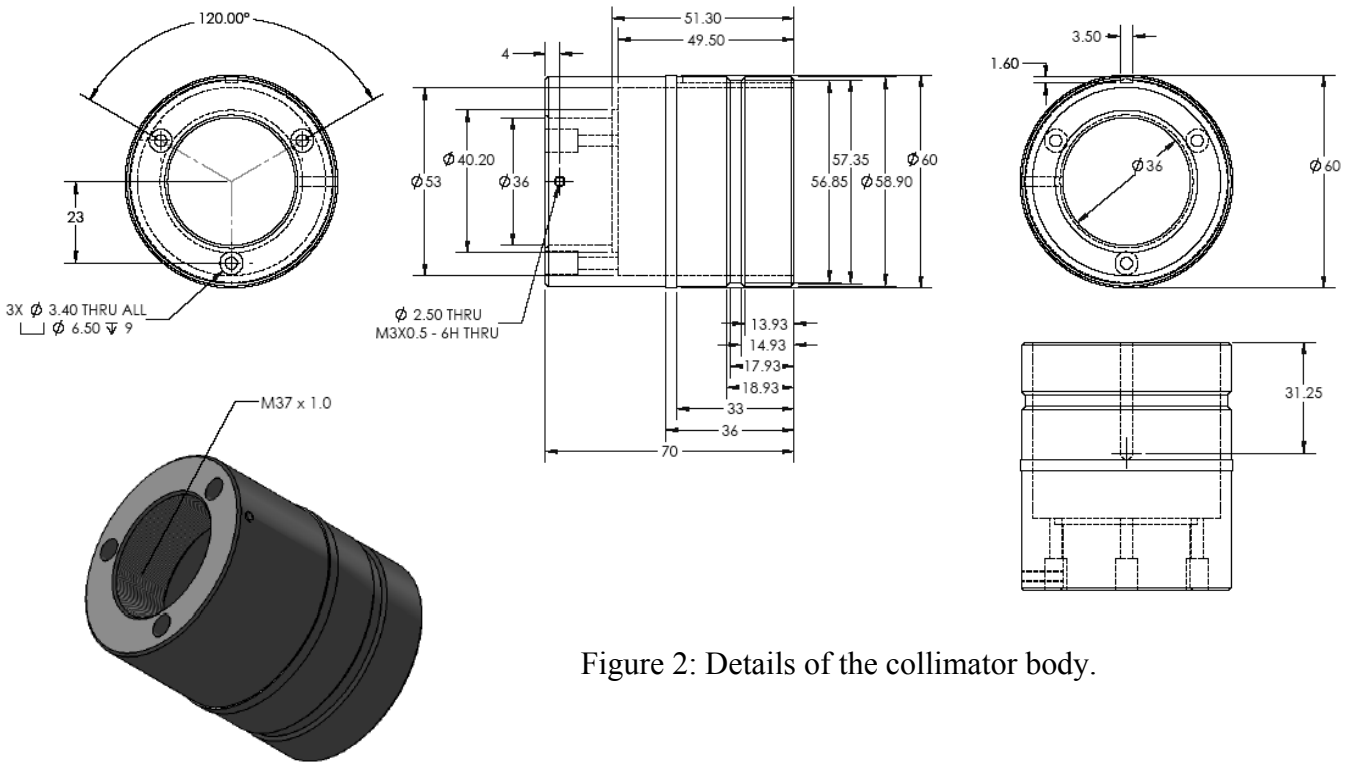
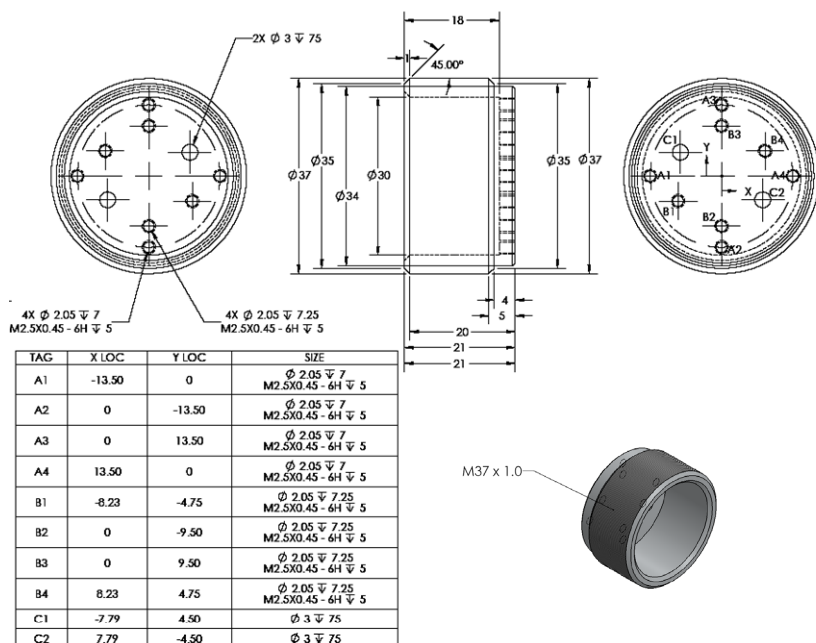

Figure 2: Details of the collimator body.

Figure 3: Details of the LED mount.



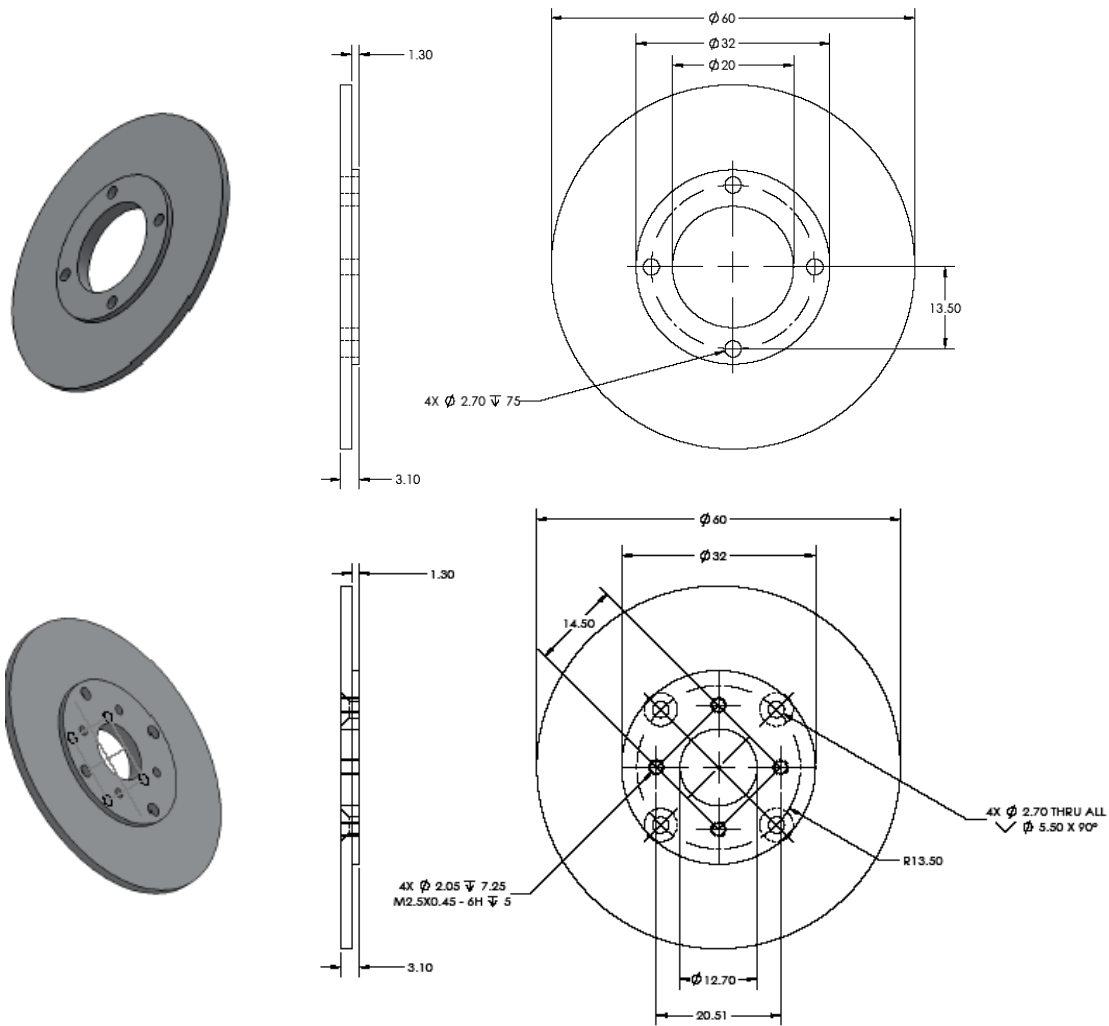

Figure 4: Details of the heatsink fins.

### 3. Illuminator power supply

The illuminator power supply is shown in Figure 5. It is constructed in a small plastic box with an on-off switch and a 1 turn potentiometer on the front panel and a fused mains input IEC connector, a control input D-type connector and the LED output connector at the rear of the unit.

It is of course essential to drive the LED with a constant current type of supply and we chose to use one of the numerous types of integrated devices for this purpose. There are ‘better’ approaches towards this, but the use of a dedicated controller simplifies the task. The circuit is shown in Figure 6 and an outline of the internal construction is shown in the next figure, Figure 7.



Figure 5: The illuminator power supply.

The particular LED controller model chosen (Recom RCD-24-1.00) only provides a maximum of one ampere of current, well below the maximum LED rating. The reason we used this particular controller and LED is not a very good one: we had both to hand! The controller is a pulse-width-modulated type and this does not produce a perfectly smooth current. The consequence is that there is some ripple present in the optical output which has the potential to cause patterning in a camera-acquired image. This is only a problem when very low camera exposures are used (~ 1 ms) and the actual beat frequency between camera line rate and LED ripple will be different with different cameras. We have not found this to be a problem at the usual exposures of 20 ms and longer.

The regulator can accept an output current control input voltage in the range of +130 mV (maximum output) to 4.5 V (minimum output), as shown in the inset of Figure 6. We used a rail-rail input/rail-to-rail output operational amplifier (MCP6291) to provide the 'correct' sense of the control voltage while allowing external 0-5V inputs. These external control inputs are summed to provide both coarse and fine setting of the LED current if required. In our systems, we use external 8 bit digital-to-analogue converters (DAC): a 255:1 level range provides insufficient resolution, hence 2 inputs. Of course if a 12-16 resolution DAC output is available, the 'fine' components can be omitted. There is nothing special about the control connections; they just happen to match an existing DAC output system.

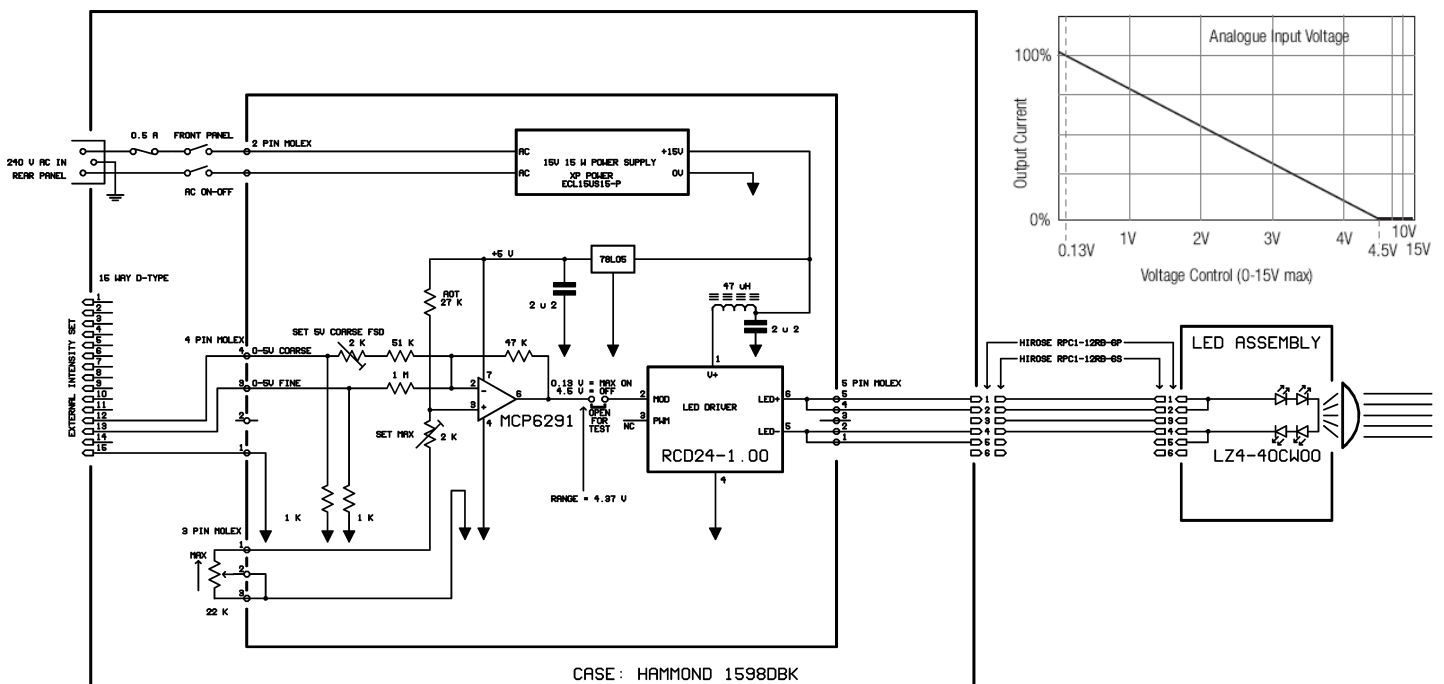

Figure 6: Circuit diagram of the LED power supply. The inset shows the control characteristic of the RCD24-1.00 LED regulator.

Primary power is supplied by a 15 V switch-mode power supply. This is somewhat over-rated (capable of producing 15 W), but has the advantage that it's cost is low and that it can be mounted directly onto a small circuit board, as shown in Figure 7. A small 5V regulator powers the operational amplifier and acts as a reference for the output intensity control.

It is noted that when external control inputs are used, the local intensity potentiometer must be set to the minimum setting: the operational amplifier output then sits at ~4.5 V and the external inputs can lower this, since the operational amplifier then operates in an inverting configuration.

It is also worth mentioning why a 6 way output connector was used, when 2 ways would have been quite sufficient. The reason is that, in the future, we may decide to use an RGB LED, to allow the possibility of acquiring colour images on a microscope fitted with a monochrome camera.

Obviously in that case the electronic would be significantly more complex, but at least we would preserve compatibility with the mechanics of the system. A slightly more dubious reason is that the particular connector chosen has minimal protrusion at its rear, simplifying construction of the heatsink fins.

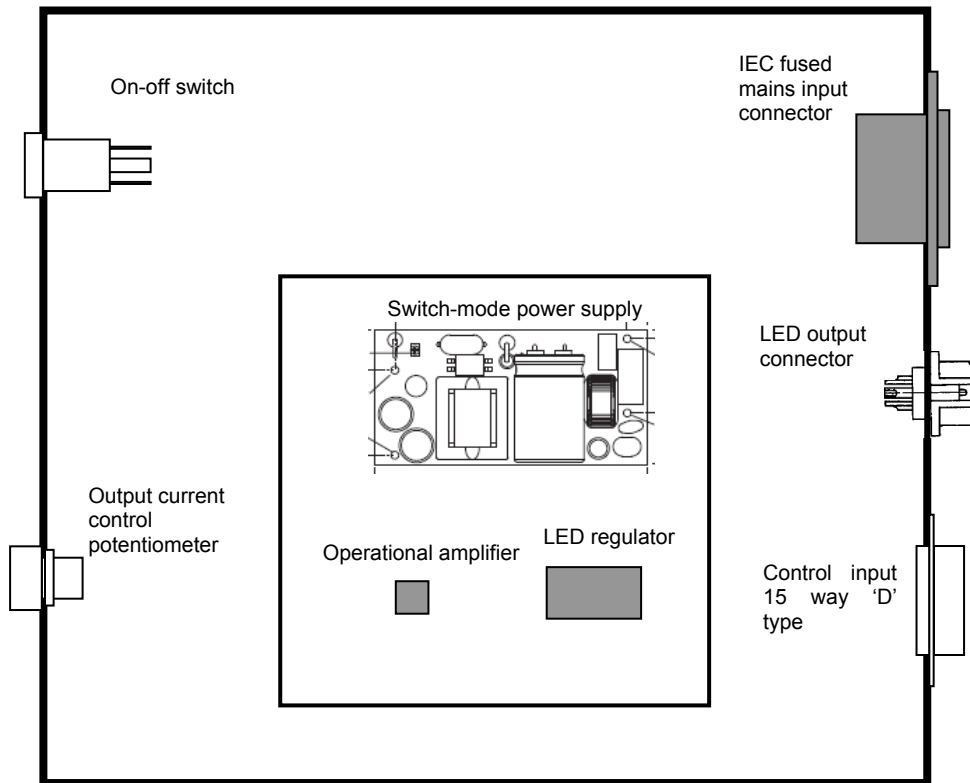

Figure 7: Internal construction of the LED power supply.

#### 4. Components for LED trans-illumination system for TE300 microscope

Item	Note	Manufacturer / model	Supplier	Qty	Price
LED power supply	Constant current driver, 0-1 A	Recom RCD-24-1.00	RS Stock 668-9870	1 off	£ 17.06
Operational amplifier	Rail-rail i/o	MCP6291-E/P	RS Stock 402-774	1 off	£ 0.412
Power supply	15W, 15V PCB mount	XP POWER - ECL15U515-P	One Call 1337083	1 off	£ 18.00
6 way LED output plug	Circular plug shell size 12	Hirose RPC1-12P-6S(73)	RS Stock 738-9035	1 off	£ 4.09
6 way LED output socket	Circular receptacle shell size 12	Hirose RPC1-12RB-6P(71)	RS Stock 738-9038	1 off	£ 1.76
IEC inlet	Includes fuse-holder	Shurter 6200.2200	One Call 9657010	1 off	£ 1.67
AC on-off switch	Mains front panel	Multicomp MC3811-091-02	One Call 9562320	1 off	£ 1.48
Potentiometer	22 k $\Omega$ 1 turn integral knob	Vishay Sfernice PA16NP223MAB15	One Call 1517313	1 off	£ 6.55
Preset	2 k $\Omega$ multiturn	Vishay Sfernice T93YA202KT20	One Call 1141402	1 off	£ 0.98
Regulator	5 V output	ST Microelectronics L78L05ABZ	One Call 1564312	1 off	£ 0.40
Inductor	47 $\mu$ H	Murata Power Solutions 18473C	One Call 2062717	1 off	£ 1.10
Capacitor	2.2 $\mu$ F	Kemet C330C225M5U5TA	RS Stock 538-1590	2 off	£ 2.152
Control signal connector	15 way D-type	Multicomp 5501-09PA-02-F1	One Call 1084672	1 off	£ 0.33
Control signal IDC cable connector 1	15 way D-type plug	F31-15-MMSS	One Call CN02270	1 off	£ 1.34
Control signal IDC cable connector 2	15 way D-type socket	F31-15-FMSS	One Call CN02273	1 off	£ 1.34
Case	180 x 206 x 64 mm	Hammond 1598DBK	One Call 722625	1 off	£ 10.67
Molex header LED output	5 way 2.54 mm pitch	Molex 22-27-2051	One Call 9731679	1 off	£ 0.61
Molex header external control	4 way 2.54 mm pitch	Molex 22-27-2041	One Call 9731164	1 off	£ 0.40
Molex header potentiometer control	3 way 2.54 mm pitch	Molex 22-27-2031	One Call 9731156	1 off	£ 0.26
Molex header mains input	3 way 5.08 mm pitch	Molex 10-16-1031	One Call CN01365	1 off	£ 0.31
Molex housing LED output	5 way 2.54 mm pitch	Molex 22-01-2055	One Call 146256	1 off	£ 0.27
Molex housing external control	4 way 2.54 mm pitch	Molex 22-01-2045	One Call 143128	1 off	£ 0.25
Molex housing potentiometer control	3 way 2.54 mm pitch	Molex 22-01-2035	One Call 143127	1 off	£ 0.24
Molex housing mains input	3 way 5.08 mm pitch	Molex 10-01-1034	One Call 143182	1 off	£ 0.29
1M resistor	Fine input range set	Vishay MRS25000C1004FCT00	One Call 9465499	1 off	£ 0.047
51 K resistor	Coarse input range set	Vishay MRS25000C5102FCT00	One Call 9468862	1 off	£ 0.047
47 K resistor	Opamp feedback resistor	Vishay MRS25000C4702FCT00	One Call 9468498	1 off	£ 0.065
27 K resistor	Manual range set	Vishay MRS25000C2702FCT00	One Call 9466517	1 off	£ 0.047
1 K resistor	Coarse, fine input pull-down resistors	Vishay MRS25 1K 1%	One Call 9465170	2 off	£ 0.13
Jumper	2 pin	FCI 68786-202LF	One Call 1740370	1 off	£ 0.157
Header for jumper	2 pin current test pins	Harwin M20-9990246	One Call 1022247	1 off	£ 0.088
					<b>£ 72.55</b>
<b>LED assembly</b>					
Light emitting diode	10 W 4-chip, white LED	Ledengin LZ4-40CW00	One Call 1678995	1 off	£ 5.40
Collimating lens	Aspheric condenser f/0.7, 40 mm dia.	Edmund	Edmund NT46-685	1 off	£ 36.00
6 way plug	Circular plug shell size 12	Hirose RPC1-12P-6S(73)	RS Stock 738-9035	1 off	£ 4.09
6 way socket	Circular receptacle shell size 12	Hirose RPC1-12RB-6P(71)	RS Stock 738-9038	1 off	£ 1.76
				<b>Total</b>	<b>£ 47.25</b>

As can be seen from the table above, total component cost is <£150, although several machined components are required. We are fortunate to have access to a mechanical workshop and it took just over one person-day to perform all the machining. Assembly of the electronics was performed in a morning so overall, the system is very cost-effective, simple to put together and very effective for time-lapse work or when a constant colour temperature is required in microscopes equipped with a colour camera.

This note was prepared in December 2012 by B Vojnovic, IDC Tullis, J Prentice and RG Newman, who also constructed the electronics; J Prentice and G. Shortland constructed the mechanical components. B Vojnovic was responsible for the overall design and IDC Tullis drew the mechanical components in SolidWorks. Although the drawings took no more than a couple of hours to complete, the files are available on request.

The financial support of Cancer Research UK, the MRC and EPSRC is gratefully acknowledged.

© Gray Institute, Department of Oncology, University of Oxford, 2012.

This work is licensed under the Creative Commons Attribution-NonCommercial-NoDerivs 3.0 Unported License. To view a copy of this license, visit <http://creativecommons.org/licenses/by-nc-nd/3.0/> or send a letter to Creative Commons, 444 Castro Street, Suite 900, Mountain View, California, 94041, USA.